

NOTES:
 1. FIRE SUPPRESSION SYSTEM CONNECTION IS NOT A POWER SOURCE. THIS CIRCUIT MUST BE CLOSED TO RUN. AN OPEN CIRCUIT WILL STOP THE GENSET.

REMOVE JUMPER FOR FIRE SUPPRESSION SYSTEM CONNECTION (SEE NOTE 1)

ECU J1-2 WHT/GRY-18GA
 OP_SENDER_SENS_GND WHT/BLK-18GA

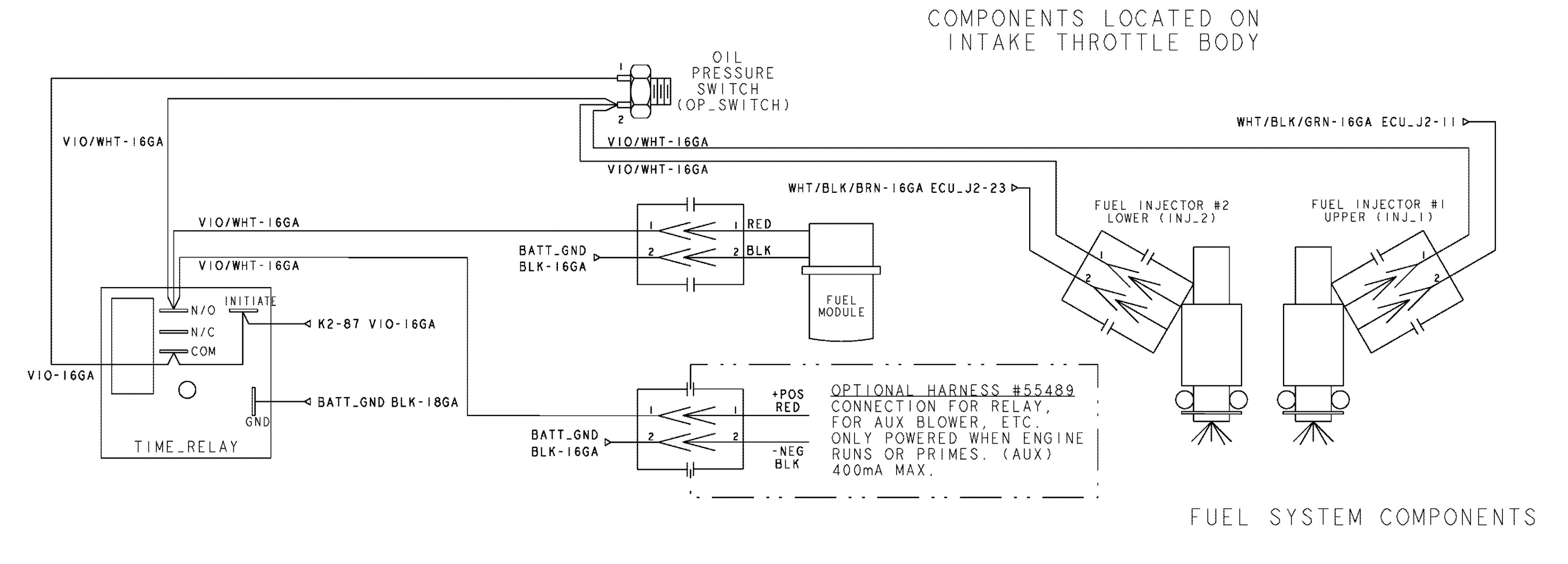
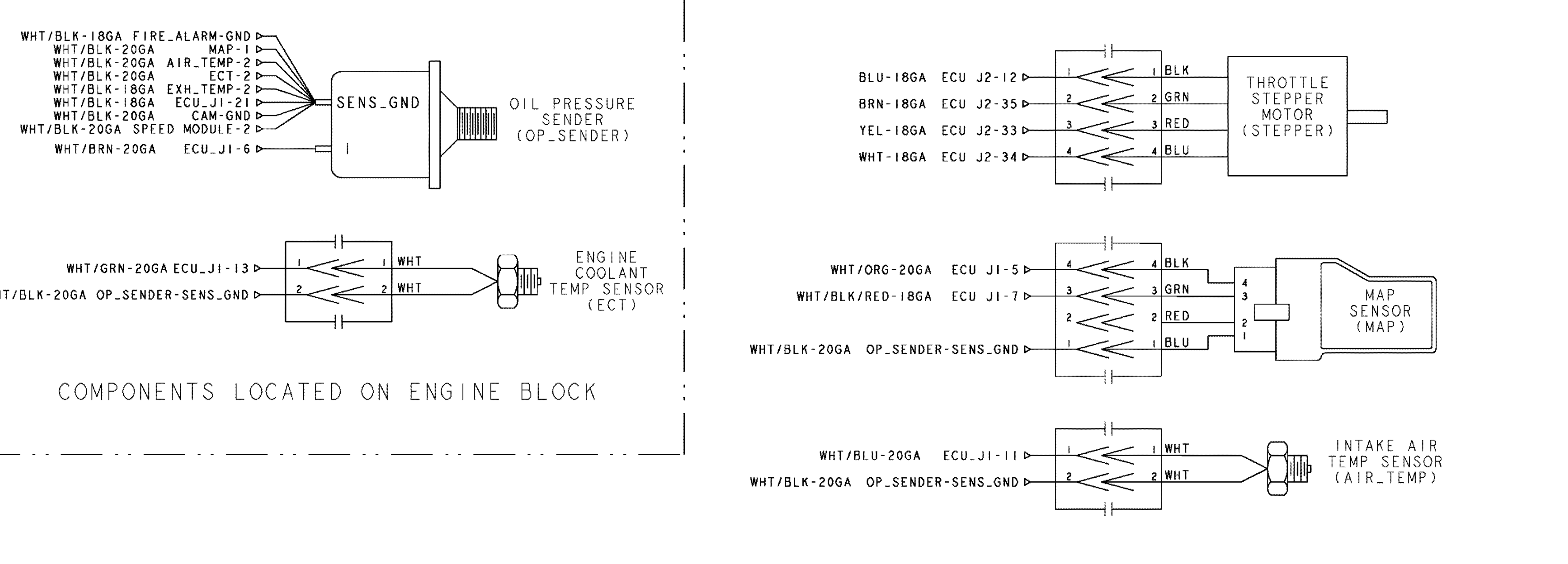
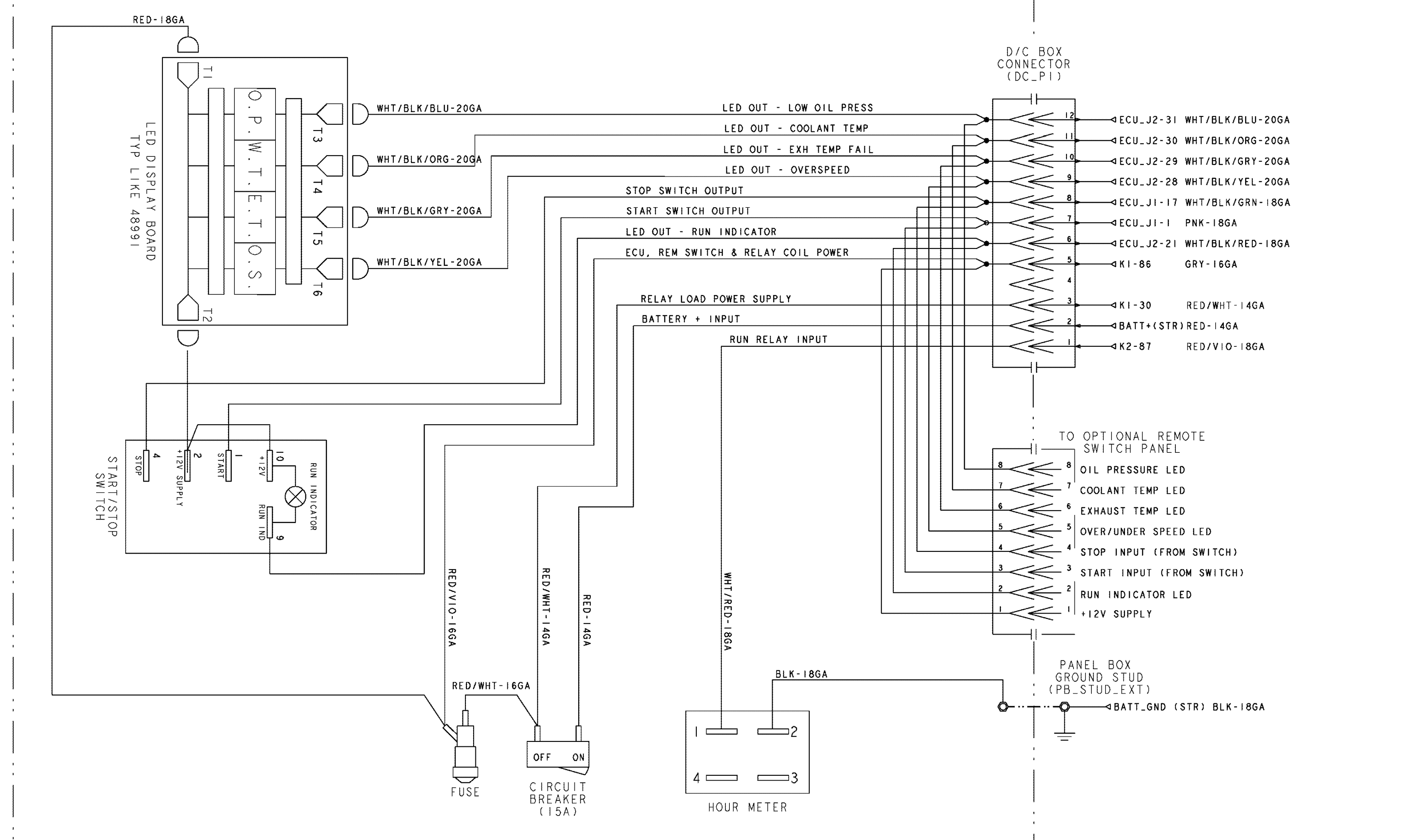
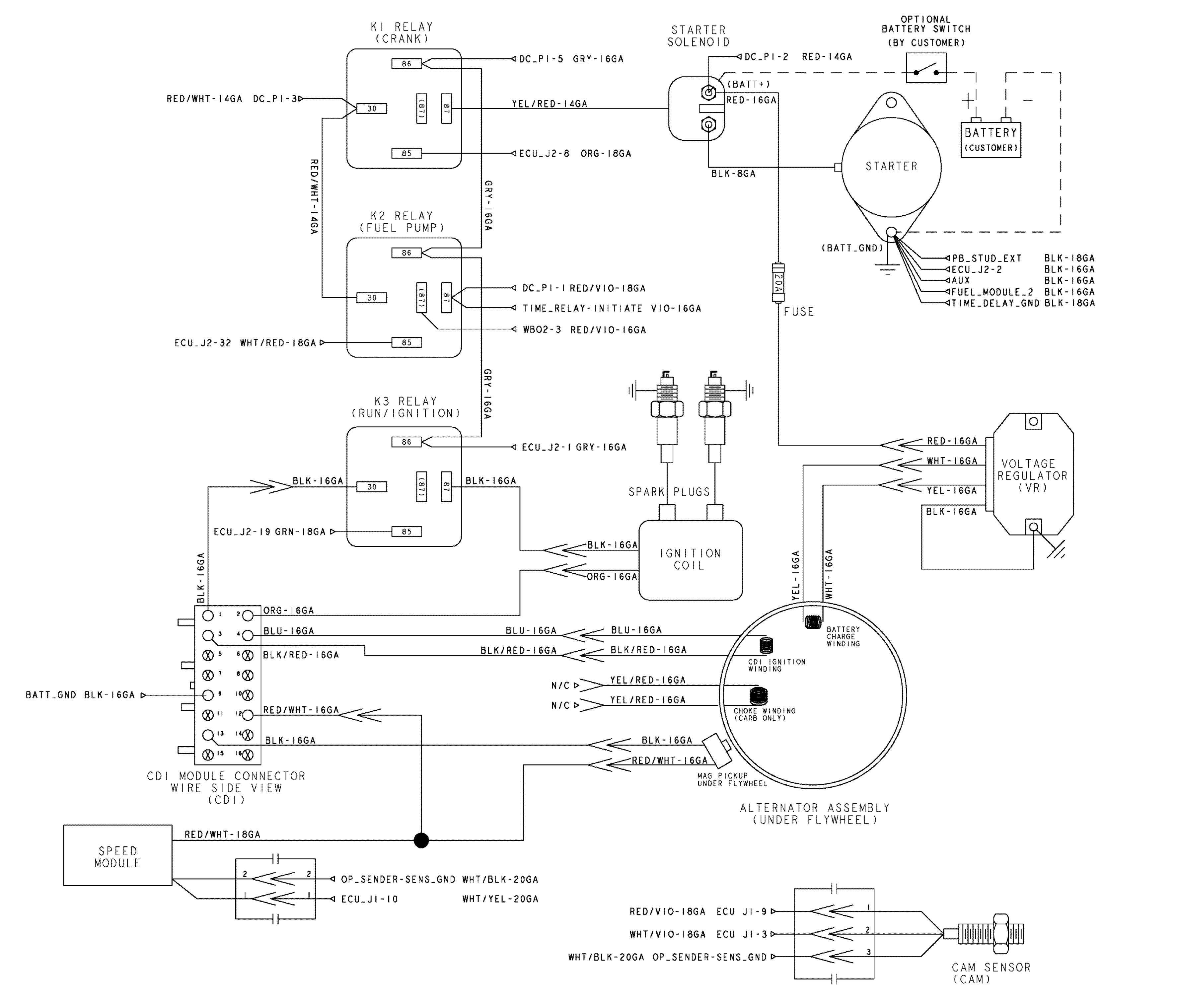

ECO NO.	DATE	REV.	REVISION RECORD	AUTH.	DR. BY
6703	8-17-2010	A	REMOVED SPEED MODULE; ADDED CRANK SENSOR	GA	
6823	8-17-2011	B	REMOVED CRANK SENSOR, ADDED SPEED MODULE RENAMED MODEL NAME TO 3.5 SCG	GA	
6831	10-26-2011	C	CAM-1 WAS CONNECTED TO K2 PIN (87). NOW IS ECU J1 PIN 9	GA	
6902	8-14-2012	D	ADD NOTE "OPTION HARNESS #55489"	GA	

TOLERANCES (UNLESS OTHERWISE NOTED)		WESTERBEKE CORPORATION TAUNTON, MA 02780	
INCHES	MILLIMETERS	TITLE	DATE
.XX ± .02	.X ± 1.0	WIRING DIAGRAM 3.5 SCG	30/Mar/10
.XXX ± .005	.XX ± .13	MULTI-PORT	
CAST ± .03			
FINISH ± .01			
DIMENSIONS	APPROVED BY	DATE	MATERIAL
INCHES	SCALE NONE	SIZE	DRAWING NUMBER
MILLIMETERS	(UNLESS APPLICABLE)	SHT. 1 OF 1	E 54609